



Robotic pallet stacker L-MATIC

Series 133

Safety

Thanks to its smart safety management, the L-MATIC anticipates and reacts autonomously to its direct environment. Advanced obstacles' detection provides real time speed adjustment to enhance the productivity while offering the utmost safety.

Performance

The unique infrastructure-free geoguidance system makes the solution flexible and scalable. Stand alone or within larger fleets of robotic trucks, the L-MATIC can easily interact with the customer's environment (doors, conveyors..) and even interface with WMS/ERP. The L-MATIC will always deliver the optimal drive speed to achieve the maximum throughput.

Comfort

The L-MATIC is natively designed to work in a shared environment with people. The user-friendly interface provides all needed controls & information at a glance. Moreover, the dual driving mode makes the L-MATIC intuitive to switch automatic/manual.

Reliability

Fully integrated in the warehouse product range, the L-MATIC benefits from all Linde quality standards, and the robust "DRIVEN BY BALYO" navigation technology. Always available, the L-MATIC will support your business 24/7 while offering significant costs-savings.

Productivity

Efficiency at work, efficiency in servicing. With a computerized & remote diagnostic system, combined with predictive maintenance program, the L-MATIC remains available at any time.

Linde Material Handling

Linde

Technical Data according to VDI 2198

Characteristics	1.1	Manufacturer		LINDE/BALYO
	1.2	Model designation		L-MATIC
	1.2a	Series		133
	1.3	Power unit		Battery
	1.4	Operation		Robotic/manual
	1.5	Load capacity/Load	Q (t)	1.2 / 2.0 ¹⁾
	1.6	Load centre	c (mm)	600
	1.8	Axle centre to fork face	x (mm)	948 (833) ²⁾
	1.9	Wheelbase	y (mm)	1625 (1510) ³⁾⁴⁾
Weights	2.1	Service weight	(kg)	1415 ⁵⁾
	2.2	Axle load with load, front/rear	(kg)	1367/1248 (1419/1996) ²⁾⁴⁾
	2.3	Axle load without load, front/rear	(kg)	1110 / 305 ⁶⁾
Wheels/Tyres	3.1	Tyres rubber, SE, pneumatic, polyurethane		Polyurethane
	3.2	Tyre size, front		Ø 254 x 102
	3.3	Tyre size, rear		2x Ø 85 x 85
	3.4	Auxiliary wheels (dimensions)		Ø 125 x 60
	3.5	Wheels, number front/rear (x = driven)		1x + 2 / 2
	3.6	Track width, front	b10 (mm)	544 ⁷⁾
	3.7	Track width, rear	b11 (mm)	380 ⁷⁾
Dimensions	4.2	Height of mast, lowered	h1 (mm)	1490
	4.3	Free lift	h2 (mm)	150
	4.4	Lift	h3 (mm)	1924
	4.5	Height of mast, extended	h4 (mm)	2460
	4.6	Initial lift	h5 (mm)	125
	4.9	Height of tiller arm in operating position, min/max	h14 (mm)	1140 / 1350
	4.15	Height, lowered	h13 (mm)	86
	4.19	Overall length	l1 (mm)	2285 ⁸⁾
	4.20	Length to fork face	l2 (mm)	1135 ⁹⁾
	4.21	Overall width	b1/b2 (mm)	804 ⁹⁾
	4.22	Fork dimensions	s/e/l (mm)	55 x 180 x 1150 ⁹⁾
	4.24	Width of fork carriage	b3 (mm)	780
	4.32	Ground clearance, centre of wheelbase	m2 (mm)	20
	4.33	Aisle width with pallet 1000 x 1200 across forks	Ast (mm)	2868 (2774) ¹⁰⁾
	4.34	Aisle width with pallet 800 x 1200 along forks	Ast (mm)	2739 (2694) ¹⁰⁾
4.35	Turning radius	Wa (mm)	2066 (1951) ¹⁰⁾	
Performance	5.1	Travel speed, with/without load	(km/h)	6/6 (max. 7.2/2.9) ⁹⁾
	5.2	Lifting speed, with/without load	(m/s)	0.11 / 0.22 (0.06 / 0.06) ⁹⁾
	5.3	Lowering speed, with/without load	(m/s)	0.3 / 0.3 (0.07 / 0.07) ⁹⁾
	5.8	Maximum climbing ability, with/without load	(%)	5.0 / 5.0
	5.10	Service brake		Electro-magnetic
Drive	6.1	Drive motor, 60 minute rating	(kW)	3
	6.2	Lift motor, rating at S3 15%	(kW)	1.7
	6.3	Battery according to DIN 43531/35/36 A,B,C,no		no
	6.4	Battery voltage/rated capacity (5h)	(V/Ah)	24 / 375
	6.5	Battery weight (± 5%)	(kg)	295
Others	8.1	Type of drive control		LAC
	8.4	Noise level at operator's ear	(dB(A))	< 70

1) Load distribution e.g. 1000 kg on the forks, 1000 kg on the fork arms. Total load max. 2000 kg.
 2) Figures in parenthesis with initial lift
 3) (± 5 mm)
 4) ± 0 mm = 3 PzS lateral; + 100 mm = 3 PzS vertical and 4PzS lateral;
 = 4 PzS vertical

5) Figures with battery, see line 6.4/6.5.
 6) (± 10%)
 7) Load arms 60x125x1119
 8) Including a 200 mm (min.) operating aisle clearance.
 9) Includes a 100mm clearance in front of front safety laser
 10) Figures in parenthesis in automatic operation, forward/backwards

Standard Equipment/Optional Equipment

Standard Equipment

- Navigation module on a robust frame with lighting signals, control panel, touch screen, communication module, navigation laser, front & rear safety scanner, traction/steering & lifting software management
- Drive wheel and tandem load wheels polyurethane
- Lateral change 3PzS
- Standard mast 1924 mm
- Fork carriage 560/1150/55 mm built out
- Pre-setting for wet battery
- Key switch truck access
- Polycarbonate mast protection
- Load detection sensor
- 3D camera for volume perception (technical conditions apply)

Optional Equipment

- Load backrest h=1000mm
- Tandem load wheels greasable
- Mesh protection
- Pre-setting for gel battery
- Fixed battery stand 2 batteries
- Mobile battery trolley 1 battery
- Cable/connector Flex
- Cable/connector Perfect
- 3 m cable extension
- 2D curtain laser
- Mobile load perception mounted on carriage (application shelves)
- Blue spots single
- Additional louder horn
- Bar code reader, call button (COMBOX), various sensors...

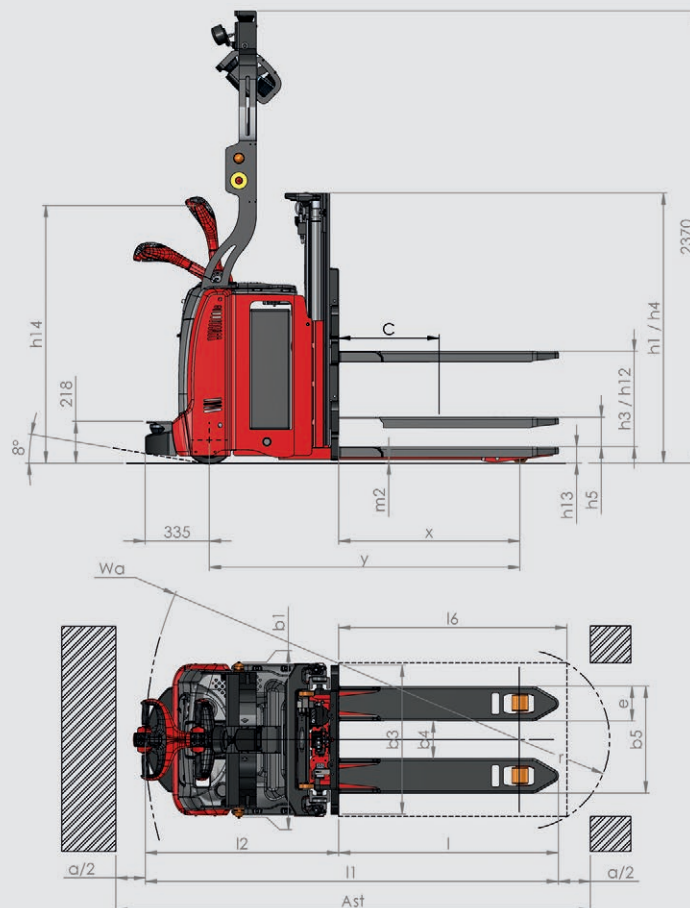

Features

Driving system

- Standard truck converted into a robotic truck
- Dual driving mode - automatic/manual
- Navigation laser, safety front & rear scanner, 3D camera, embedded computer, emergency stop buttons, light and sound warning indicators



Geoguidance navigation

- Innovative infrastructure-free technology (no reflector)
Relies on existing structural features (walls, columns, racks...)
- Real time mapping and localization
- Seamless integration in existing layouts, gradual extension or global deployment



Smart safety

- Real time speed-adaptive detection fields
- Dynamic cornering detection fields
- Autonomous decision-making capability with 3D camera
- Natural cohabitation with operators and other trucks
- Pallets or obstacles detection thanks to the rear laser scanner

User interface

- 7" LCD touch screen
- Robotic truck, battery and system status
- Real time task management and report
- 3 Intuitive path localization
- Service mode with PIN access
- Log extraction via USB

Operations management

- Stock line management (using front scanner)
- Stand alone or WMS/ERP directed
- Supervisor software for task and smart traffic management
- Various task triggers: call buttons, sensors, PLCs, Supervisor software ...

Subject to modification in the interest of progress. Illustrations and technical details could include options and not binding for actual constructions. All dimensions subject to usual tolerances.



ncnielsen

Nørregade 66, DK-7860 Balling | Tlf.: +45 99 83 83 83
nc-nielsen.dk | info@nc-nielsen.dk