



# ELECTRIC PALLET TRUCK MT12

**CAPACITY 1200 KG | SERIES 1131-00**

## **Safety**

The MT12 features an effective parking brake to hold the truck safely on slopes or on lorry tail lifts. A robust metal cowling protects the drive unit and components, while the low profile chassis protects the operator's feet. A long, low mounted tiller arm places the operator at a safe yet comfortable working distance from the truck.

## **Performance**

The MT12 has been specially designed for light duty applications in small retail stores, production lines, warehouses or goods transport sectors. Thanks to its powered traction and lift, the operator's physical input is minimized. Equipped with a 0.65 kW drive motor, the MT12 offers a highly cost-effective and productive solution for short distance transfer of loads up to 1200 kg. Its compactness guarantees maximum manoeuvrability when operating inside lorries or confined spaces.

## **Comfort**

The compact and exchangeable Li-ION batteries allows opportunity charging via the external charger at any convenient power point for

optimum uptime. All controls located on the ergonomic tiller. The dual butterfly levers for traction and the lifting function can be easily operated by either hand to ensure precise operation.

## **Reliability**

The durable drive unit of the MT12 delivers consistent high performance and reliability. The robust chassis has a reinforced fork structure for safe, efficient handling of loads up to 1200 kg. The automatic lift stop at maximum lift height improves the quality and durability of components, protects the pump unit and reduces noise.

## **Service**

The DC drive motor optimizes uptime between routine service periods and reduces service costs, while a reliable, energy efficient controller delivers smooth handling performance. All truck data is immediately and easy accessible to the service engineer via the CAN-bus architecture.

# TECHNICAL DATA

ACCORDING TO VDI 2198

Characteristics	1.1	Manufacturer		LINDE
	1.2	Model designation		<b>MT12</b>
	1.3	Power unit: Battery, diesel, gasoline, LPG		Battery
	1.4	Operation		Pedestrian
	1.5	Load capacity	Q [t]	1.2
	1.7	Load center	c [mm]	600
	1.9	Axle center to fork face	x [mm]	950 (880)
	1.1	Wheelbase	y [mm]	1190 (1120)
Weight	2.1	Service weight	[kg]	130
	2.2	Axle load with load, front/rear	[kg]	420 / 910
	2.3	Axle load without load, front/rear	[kg]	110 / 20
Wheels and types	3.1	Tyre: SE=(superelastic), P=(pneumatic)		PU/PU
	3.2	Tyre size, front	mm	210x70
	3.3	Tyre size, rear	mm	80x60
	3.5	Wheels, number front/rear (X=drive)		1x+/4
Dimensions	4.4	Lift	$h_3$ [mm]	110
	4.9	Height of tiller arm in driving position, min/max	$h_{14}$ [mm]	800/1190
	4.15	Fork height, lowered	$h_{13}$ [mm]	80
	4.19	Overall length	$l_1$ [mm]	1540
	4.20	Length to fork face	$l_2$ [mm]	390
	4.21	Overall width	$b_1 / b_2$ [mm]	560(685)
	4.22	Fork dimensions $s \times e \times l$	$s \times e \times l$ [mm]	53x150x1150
	4.25	Distance between fork- arms	$b_5$ [mm]	560(685)
	4.32	Ground clearance with load, center of wheelbase	$m_2$ [mm]	27
	4.34	Aisle width, 800 x 1200 along forks	$A_{st}$ [mm]	2062
4.35	Turning radius	$W_a$ [mm]	1390	
Performance	5.1	Travelling speed, with/without load	[km/h]	4.0 / 4.5
	5.2	Lifting speed, with/without load	[m/s]	0.02 / 0.025
	5.3	Lowering speed, with/without load	[m/s]	0.06 / 0.03
	5.8	Max. gradeability, laden/ unladen	%	4 / 10
	5.9	Acceleration time with/without load	[s]	n/a
	5.10	Service brake		Electric
Drive Unit	6.1	Drive motor rating S2 60 min	[kW]	0.65
	6.2	Lift motor rating at S3 10 %	[kW]	0.5
	6.3	Battery acc. to DIN 43531/ 35/ 36 A, B, C, no		Li-ion
	6.4	Battery voltage, nominal capacity K5	[V/ Ah]	24 / 20
	6.5	Battery weight	kg	3.7
	6.6	Energy consumption acc. to VDI cycle	[kW/h]	n/a
Other	8.1	Type of drive control		DC
	8.4	Noise level	[dB (A)]	<74

# STANDARD EQUIPMENT / OPTIONAL EQUIPMENT

## STANDARD EQUIPMENT

Drive wheels polyurethane

Tandem polyurethane load wheels

4.5 km/h travel speed

Li-ION Battery 24 V / 20 Ah

Plug: EU type

Switch - USB type

Electromagnetic brake

Automatic parking brake

Forks: 1150 x 560 mm

Belly switch on tiller head

CAN bus technology

## OPTIONAL EQUIPMENT

Drive wheel polyurethane wet grip

Single polyurethane load wheel

Alternative fork lengths and widths

Extra battery Li-ION 24 V / 26 Ah

Load backrest 1220 mm & 1520 mm high

Plug: UK type

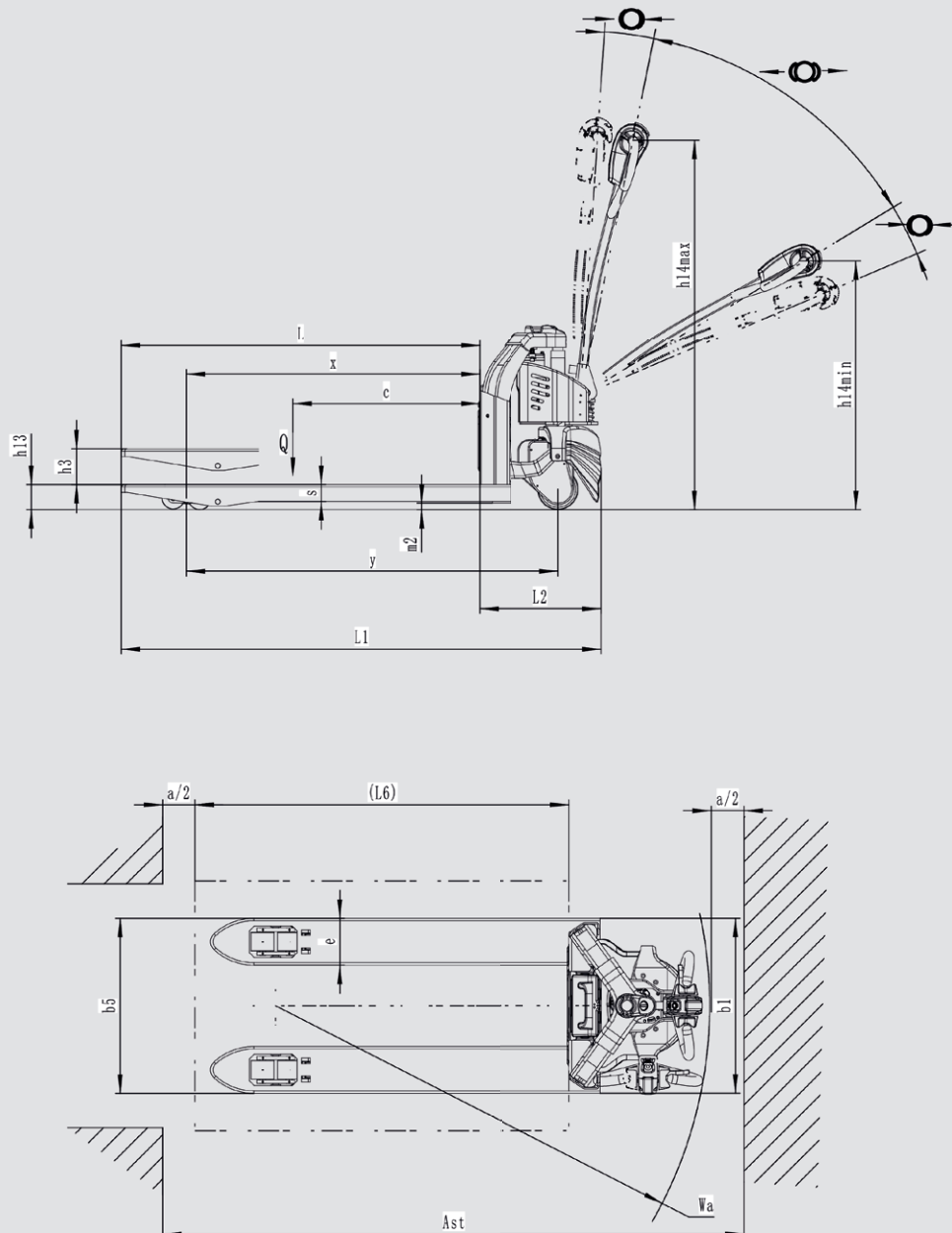

# FEATURES

## Traction and lift system

- 0.65 kW DC drive motor
- Adjustable parameters:
  - travel speed up to 4.5 km/h
  - & acceleration
- Electrical lifting
- Manual lowering

## Chassis

- Robust metal cover protects drive system and components
- Low chassis skirt protects operator's feet
- Long, low mounted tiller ensures operator is safe yet comfortable distance from the truck
- Rugged, reinforced fork structure provides safe handling of loads up to 1200 kg



## Braking system

- Highly efficient electromagnetic brake applied by moving the tiller to fully up or down position
- Automatic braking on releasing traction butterfly or reversing direction
- Truck slows before coming to a stop, remaining under total control at all times
- Proofed emergency button

## Display

- Reliable and precise battery discharge indicator
- Operating hour meter
- Faults code indication
- Battery management system



## Battery

- Plug and play system
- Li-ION technology
- 20 Ah (standard) and 26 Ah (option)
- Up to 3 h autonomy
- 2.5 h charging time

## External charger

- Enables opportunity charging at any convenient power point
- Easy plug and fast charging
- Wall mounted

## Controls

- Traction and lift controls grouped on ergonomic tiller head
- Dual butterfly control levers for use with either hand
- Control lever for manual lowering
- Belly switch on tiller head stops truck when actuated
- Key switch - USB type

Subject to modification in the interest of progress. Illustrations and technical details could include options and not binding for actual constructions. All dimensions subject to usual tolerances.

**ncnielsen**

Nørregade 66, 7860 Balling | Metalgangen 1, 2690 Karlslunde  
Tel: 99 83 83 83 | nc-nielsen.dk | info@nc-nielsen.dk

Linde Material Handling

*Linde*