



Electric Tow Tractor Capacity 25000 kg P 250

Series 127-03

Safety

The heavy duty chassis and cab module provide assured protection for the operator while three independent braking systems deliver responsive stopping power for all situations including automatic speed control descending gradients. A low centre of gravity ensures outstanding stability.

Performance

With a nominal towing capacity of 25.0 tonne and unladen traction speed of 25 km/h the P 250 offers flexible high performance which is optimised by the Linde digital AC control system providing precise, energy saving control of acceleration and speed for high productivity. The curved front screen and profiled chassis ensures excellent manoeuvrability.

Comfort

A low step facilitates access to spacious operator's cabin where the automotive layout of the pedals, direction lever, steering wheel and controls, together with a fully adjustable suspension seat provides a comfortable and fatigue-free working environment. Cab suspension dampers and a spring damped suspension system front and rear ensures superb levels of driving comfort.

Reliability

Designed for intensive heavy duty applications the rugged, robot-welded chassis is constructed from heavy section steel plate for optimum torsional stiffness and rounded corners for high resistance to impacts. All key components are protected within the chassis while electronic components are housed in sealed aluminium enclosures for assured reliability & long life.

Service

Two powerful, high torque 10 kW AC drive motors provide impressive pulling power for a variety of intensive applications. The energy saving Linde AC digital controller combined with excellent manoeuvrability and an intuitive interface between the operator and tractor, translates that power into versatile, seamless performance and high productivity.

Linde Material Handling

Linde



Standard Equipment/Optional Equipment

Standard Equipment

General

Four wheel configuration
Pneumatic tyres
Tractor without cab
Left or right hand drive steering position
Adjustable steering column
Comprehensive integrated display
Single pedal accelerator and direction lever
Full suspension PVC driver's seat
Non-suspension PVC passenger seat
Hydrostatic power steering
Two exterior mirrors
Remote inching control
Automatic single position, rear towing coupling
Trailer lighting socket
Dual circuit hydraulic disc brakes on all four wheels
Standard colour scheme - vermilion and charcoal grey
Full road lighting
Heated rear screen (with full cabin)

Electronics

80 V circuit/highly efficient energy saving system
2 x 10 kW maintenance free AC drive motors
Advanced Linde AC digital controller
Precise control of speed and acceleration
Programmable performance parameters

Batteries and chargers

P 250 SWB - 80V, 400 to 620 Ah to IEC
P250 LWB - 80V, 600 to 930 Ah to IEC
Easy vertical lift out battery change
A range of chargers is available to suit application

Safety

Keyswitch
Emergency circuit isolator/Fails to safe circuitry
Traction isolated by seatswitch and/or parking brake
Electrical overload protection
Comprehensive warning lights
Electric horn

Optional Equipment

Cab with flexible roll up sides
Cab without sides
Cab with sliding or hinged doors
Optional cab with front and rear screen wipers/washers
Rear lights mounted high at rear of cab
Flashing or rotating beacon on cab
Reverse warning beeper
Contoured solid (superelastic) tyres
Towing couplings:
- Automatic single position, front and/or rear
- Automatic single position, remote, rear
- Multi-position, front and/or rear

240 mm rear coupling extension
Electric or diesel heater and demister
Fabric covered seats
Heated seats
Full suspension passenger seat
Alternative colour schemes

Technical Data according to VDI 2198

| | | | | | |
|---|------------|---|---|--------------------------------|--------------------------------|
| Characteristics | 1.1 | Manufacturer | | LINDE | LINDE |
| | 1.2 | Model designation | | P250 (SWB)³⁾ | P250 (LWB)³⁾ |
| | 1.3 | Power unit | | Battery | Battery |
| | 1.4 | Operation | | Seat | Seat |
| | 1.5 | Load capacity | Q (t) | 25.0 ³⁾ | 25.0 ³⁾ |
| | 1.7 | Rated tractive force | F (N) | 5000 ³⁾ | 5000 ³⁾ |
| | 1.9 | Wheelbase | y (mm) | 1465 | 1900 |
| Weights | 2.1 | Service weight | (kg) | 3800 | 4800 |
| | 2.2 | Axle load with load, front/rear | (kg) | 2000 / 2100 | 2600 / 2500 |
| | 2.3 | Axle load without load, front/rear | (kg) | 1900 / 1900 | 2500 / 2300 |
| Wheels/Tyres | 3.1 | Tyres rubber, SE, pneumatic, polyurethane | | Pneumatic | Pneumatic |
| | 3.2 | Tyre size, front | | 6.00 R9 | 6.00 R9 |
| | 3.3 | Tyre size, rear | | 7.00 R12 | 7.00 R12 |
| | 3.5 | Wheels, number front/rear (x = driven) | | 2 / 2x | 2 / 2x |
| | 3.6 | Track width, front | b10 (mm) | 1080 | 1080 |
| | 3.7 | Track width, rear | b11 (mm) | 1020 | 1020 |
| | Dimensions | 4.7 | Height of overhead guard (cabin) | h6 (mm) | 1820 |
| 4.8 | | Height of seat/stand-on platform | h7 (mm) | 745 | 745 |
| 4.12 | | Towing coupling height | h10 (mm) | 240, 295, 350, 405 | 240, 295, 350, 405 |
| 4.13 | | Platform height, unladen | h11 (mm) | 1000 | 1000 |
| 4.16 | | Loading platform, length | l3 (mm) | 1520 | 1955 |
| 4.17 | | Rear overhang | l5 (mm) | 615 | 615 |
| 4.18 | | Loading platform, width | b9 (mm) | 1170 (1120) ³⁾ | 1170 (1120) ³⁾ |
| 4.19 | | Overall length | l1 (mm) | 3045 | 3480 |
| 4.21 | | Overall width | b1/b2 (mm) | 1300 | 1300 |
| 4.32 | | Ground clearance, centre of wheelbase | m2 (mm) | 150 | 150 |
| 4.35 | | Turning radius | Wa (mm) | 2830 | 3280 |
| 4.36 | | Minimum pivoting point distance | b13 (mm) | 935 | 1095 |
| Performance | | 5.1 | Travel speed, with/without load | (km/h) | 11 / 25 ³⁾ |
| | 5.5 | Tractive force, with/without load | (N) | 5000 | 5000 |
| | 5.6 | Maximum tractive force, with/without load | (N) | 16000 | 16000 |
| | 5.7 | Climbing ability, with/without load | (%) | see performance graph | see performance graph |
| | 5.8 | Maximum climbing ability, with/without load | (%) | see performance graph | see performance graph |
| | 5.10 | Service brake | | Electric/hydraulic | Electric/hydraulic |
| Drive | 6.1 | Drive motor, 60 minute rating | (kW) | 2x 10 | 2x 10 |
| | 6.3 | Battery according to DIN 43531/35/36 A,B,C,no | | 43 536 / A | 43 536 / A |
| | 6.4 | Battery voltage/rated capacity (5h) | (V/Ah) | 80 / 620 | 80 / 930 |
| | 6.5 | Battery weight (± 5%) | (kg) | 1558 | 2178 |
| | 6.6 | Power consumption according to VDI cycle | (kWh/h) | upon request | upon request |
| | Others | 8.1 | Type of drive control | | AC - microprocessor |
| 8.4 | | Noise level at operator's ear | (dB(A)) | upon request | upon request |
| 8.5 | | Towing coupling, design/type, DIN 15 170 | | upon request | upon request |
| 1) Based on level, dry surface with rolling resistance of 200 N/t. Refer to towing. 2) at rear | | | 3) 72 V circuit available Traction speed is reduced by 10%. | | |

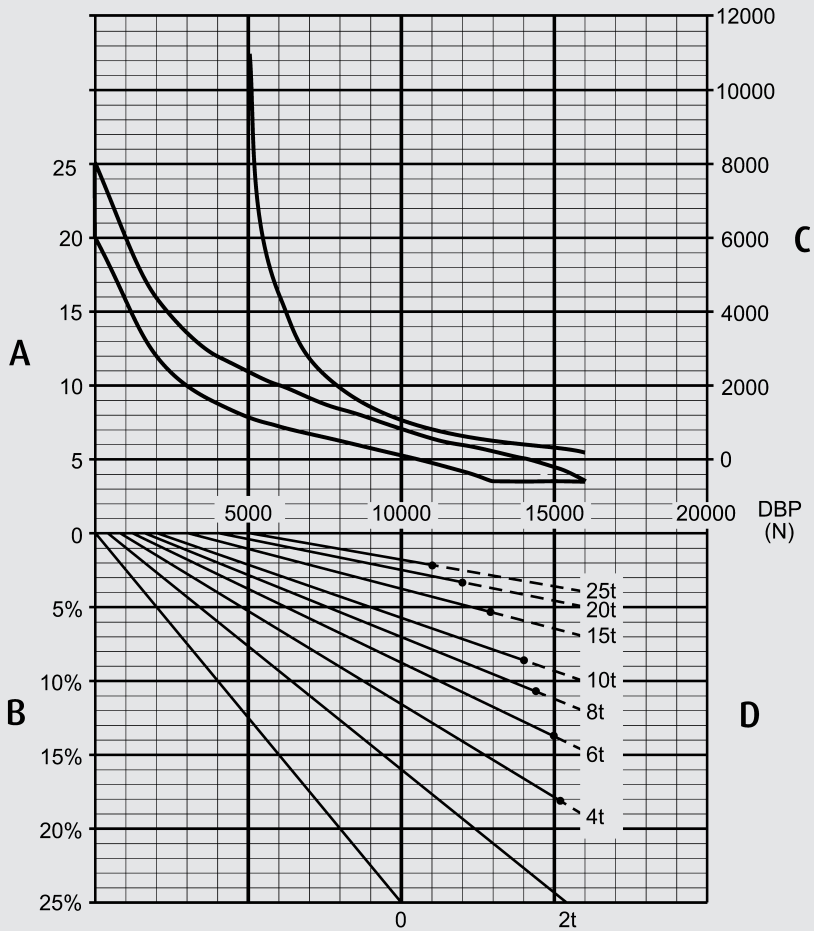
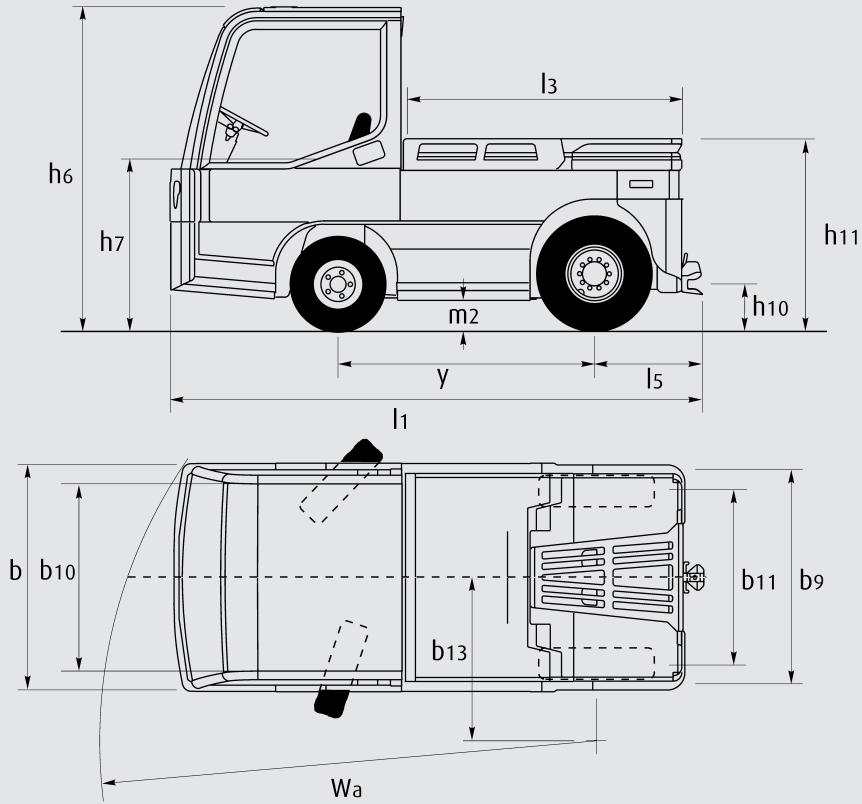

| | |
|-----|--|
| A = | Speed (km/h) |
| B = | Gradient |
| C = | Permissible haul per hour (m) |
| D = | P (N) drawbar pull |
| E = | Combined weight (trailed plus carried) |

Comment on diagram

Load/gradient combination by full line can be raised from stationary on the gradient. The permissible haul per hour is the total distance travelled, including the return journey and any downhill gradients. It is recommended that braked trailers are used for trailer loads exceeding 9 tons and for all trailer loads where a gradient is involved.

Features

Chassis

- Long and short wheelbase versions
- Robot welded heavy gauge steel plate
- Maximum torsional resistance and rigidity
- High impact protection for operator and components
- Low profile chassis for all-round visibility



Ergonomics

- Ergonomic automotive pedal and control layout
- Spacious leg and headroom
- Storage space for documents, pens and beverage holder
- Excellent all-round visibility
- Clear view to rear tow coupling

Operator's compartment

- Low step access to spacious cabin
- Sliding or hinged cabin doors
- Fully adjustable comfort-class operator's seat
- Cabin isolated from chassis by hydraulic dampers
- Multi-function instrument display



Steering

- Hydrostatic power steering
- Effortless manoeuvrability
- Adjustable steering column
- Large lock-to-lock angle

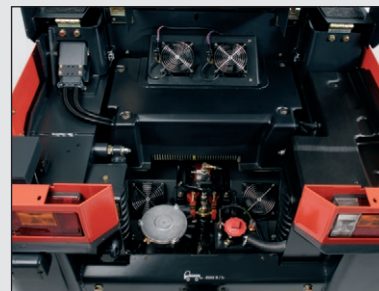

Braking

- Three independent braking systems
- Electric push-button parking brake
- Hydraulic disc brakes (front) external disc brakes (rear)
- Regenerative electric braking as accelerator pedal is released
- Superb regenerative braking control on gradients



Tow coupling

- Automatic rear towing coupling as standard
- Optional remote automatic and multi-position couplings
- Front and rear towing coupling options
- Stand-off inching control as standard

Drive unit

- Two 10 kW maintenance-free AC drive motors
- Integrated in drive axle with no differential required
- Superb traction with anti-slip control
- Reduced power to inner wheel during cornering
- High-torque flexibility and performance

Serviceability

- Hinged rear platform cover
- Easy access for maintenance and battery
- CAN bus diagnostic facility for reduced service intervals
- Multi-function instrument display assists scheduled maintenance planning
- Maintenance-free AC drive technology

ncnielsen

7860 Balling · tlf: 99 83 83 83 · fax: 97 56 46 24
e-mail: linde@nc-nielsen.dk · www.nc-nielsen.dk

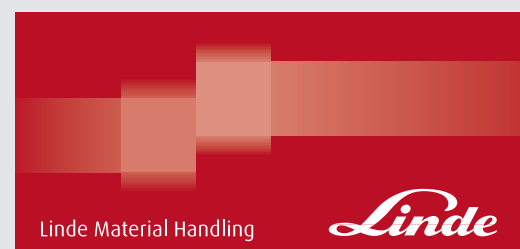

Subject to modification in the interests of progress. Illustrations and technical details not binding for actual constructions. All dimensions subject to usual tolerances.

085.e.3.0111.indB.KI