

ENGINE

Cummins QSB6.7-190 (Tier 4f/Stage 4)

Six-cylinder four-stroke direct injection diesel engine with variable geometry turbo charging and intercooler.

Engine equipped with Cummins (AdBlue) system including DOC and SCR-catalyst.

Displacement:6,7 dm³

Bore: 107 mm

Stroke: 124 mm

Compression ratio: 17,2 : 1

Output:..... 142 kW (193 hp) at 2000 rpm

Torque:..... 809 Nm at 1500 rpm

Acc. to ECE R120

Only for use outside EU/US/Canada:

Cummins QSB6.7-173 (Tier 3/Stage 3A)

Mercedes OM906LA (Tier 3/Stage 3A)

Cummins ISB6.7E5-205 (Euro 5)

GEARBOX

Allison, type 3000

Automatic shift transmission with 5 gears forward, 1 gear reverse and torque converter equipped with Lock-Up clutch. Including standard F/R shift protection.

Gear ratio's	theoretical speed (2200rpm) [km/h]	
3.487	8	(F1)
1.864	19	(F2)
1.409	25	(F3)
1.00	35	(F4)
0.75	47	(F5)

Note: speed is 37km/h@1725 engine rpm

5.027 6 (R)

(Tyre size 11R22.5, axle ratio 11.98:1)

Optional:

ZF, type 5WG191 with Lock-Up*

- Powershift transmission with high efficiency torque converter with Lock-Up clutch and 5 gears forward and 3 gears reverse.

* Only i.c.w. rear axle ratio >11.90:1

FRONT AXLE

Terberg TTA type 60-xx

Non-driven steering axle

Capacity: 10.000 kg (at 20 km/h)*

Optional:

Volvo

Non-driven steering axle

Capacity 11.000 kg (20 km/h)*

Terberg TTA62-xx

Capacity: 11.000 kg (at 20 km/h)*

* Actual axle load capacity depending on tyre load rating.

REAR AXLE

Terberg TTA type 70-11

Capacity 30.000 kg (at 20 km/h)*

Hub reduction axle with total reduction ratio 11.98:1

Optional:

- TTA 70-01 9.49:1
- D81PL478 9.76:1, 12.73:1 or 16.13:1
- D81 PL477 13.2:1 or 16.36:1

* Actual axle load capacity depending on tyre load rating.

SUSPENSION

Front: Parabolic leaf springs in rubber mountings with 2 telescopic shock absorbers.

Maintenance-free system.

Rear: Directly bolted to chassis frame.

Optional:

- Air suspension with rubber stops

RIMS AND TYRES

Tyres: 11R22.5 (6 pieces)

Rims: 10 stud disc wheels 22.5 x 8.25

STEERING SYSTEM

Fully hydrostatic orbital steering system with priority valve and double acting steering cylinder.

Emergency steering property.

Steering wheel diameter 350 mm

Turning circle over front bumper (m)

WB 3100 13,0

WB 3300 13,5

WB 3500 14,1

5th WHEEL

Terberg 2" cast steel plate

Technical capacity 36.000 kg.

Lifting capacity 31.000 kg*.

Automatic locking of jaw system. Pneumatic unlocking of 5th wheel, operated from cabin.

Indicator light for positive locking inside the cabin.

Optional:

- 27.000 kg* lifting capacity (for ultra low 5th wheel height)
- 34.000 kg* lifting capacity

* Actual lifting capacity depending on tyre load ratings and 5th wheel height.

HYDRAULIC SYSTEM

Engine driven hydraulic pump for steering and lifting 5th wheel plate, directly mounted to the engine, with priority valve for the steering system.

Hydraulic oil tank protected mounted to the chassis frame. Tank capacity 50 dm³.

Hydraulic valve pneumatically operated from inside the cab to lift/lower/hold the 5th wheel. Working pressure 250 bar.

2 heavy-duty hydraulic single stage lift rams.

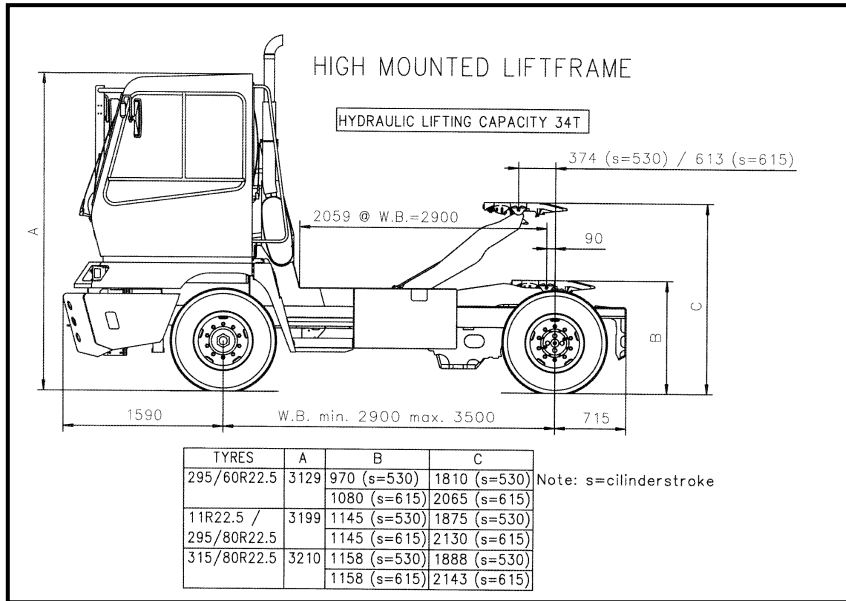

CHASSIS

Welded construction of rolled steel channels 200x100x10 mm

Air reservoirs and fuel tank protected mounted to the chassis, access steps with anti-slip surface integrated in chassis.

Towing pin attachment at front- and rear of chassis.

BRAKE SYSTEM

Full air brake system with split front and rear axle and parking brake circuits. Parking brake working on rear axle.

TTA front and rear axles equipped with S-cam brake system with automatic slack adjusters.

Kessler rear axles with simplex wedge brake (D81PL478) or single jaw disc brake (D81PL477). All with auto slack adjusters.

Brake pressure: 7,8 – 8,5 bar.

Air reservoirs: 2 x 40 dm³ and 1 x 30 dm³ with standard air dryer.

2 Line trailer brake system mounted on rear side of cabin, with yellow and red spiral hoses with gladhands.

FUEL TANK

Capacity 200 dm³ and integrated with hydraulic tank.

COOLING SYSTEM

Plate and bar type radiator of heavy-duty construction mounted on rubber silent blocks with separate air to air transmission oil cooler and engine intercooler all mounted side by side.

EXHAUST

Vertically mounted silencer with curved end pipe and protected in critical areas with stainless steel protection grilles.

ELECTRICAL SYSTEM

24 Volt negative earth.

Alternator : 28V/95A (Cummins T4f)

Batteries : 2 x 12 Volt / 140 Ah

Output starter: 4,8 kW (Cummins T4f)

Fuses and relays mounted in central electrical box.

Wiring with code numbers and easy readable/visible/accessible mounted in central electrical box.

7 pin SAE socket at rear of cab for trailer connection (DIN ISO 1185).

LIGHTING

H4 head lights with dipped and main beam and direction indicators.

LED rear lights on rear of chassis, with direction indicators and brake lights.

5th wheel flood light behind cabin.

Gauge illumination.

Interior light in cabin.

Mounting for rotating beacon light.

CABIN

1 person left-hand or right-hand drive position.

Forward facing driver's position.

Dimensions outside:

- width : 1400 mm
- length : 1593 mm
- height : 1821 mm

Cabin construction of overdimensioned strong steel profiles to comply to latest Rops/Fops regulations.

Cab mounted on 3 anti-vibration mounts in combination with shock absorber.

Entrance to cab by inboard door for safe and easy entrance/exit to/from driver's position.

Horizontal sliding window at driver's side
 Large windows with excellent visibility.
 All window panes tinted hardened safety glass except front window which is layered.

Noise insulation exceeds international standards.

Cabin can be tilted with hydraulic hand pump to 65°

Driver's seat with air suspension and fully adjustable, mounted on console with generous storage space.

Demister/heater with 3-speed blower and recirculation system.

Steering column with 1 brake pedal and 1 accelerator pedal, mounted at right side of column.

Front dashboard switches:

- Ignition
- Differential lock
- Work light
- Hazard lights
- Lighting
- 5th wheel unlocking (2x)

Dashboard display:

Multifunctional full colour CAN-bus display (DIM) showing vehicle speed , brake pressure circuit 1+2, diesel and AdBlue level and engine rpm.

With possibility to read out running hrs, as well as the following analogue values (all with optical signal and buzzer on critical levels):

- * High temperature gearbox
- * Low oil pressure engine
- * High temperature engine
- * Low voltage

Indicator lights are integrated in the display. It has also integrated diagnostic and vehicle history info which can be shown on the screen and downloaded via USB.

Steering column:

- Combi switch for:
 - * Direction indicators
 - * Wiper front
 - * High/Low beam
 - * Horn

Optional:

- Co-driver foldaway seat