

TRACTION MOTOR

Siemens

Output:.....138 kW @2000-2500 rpm
 Torque:..... 780@Nm 0-1800 rpm
 Max. engine speed.....2500 rpm
 Cooling..... liquid cooled

TRACTION CONTROLLER

Siemens

Max power: 227 kW
 Cont. current 250 A
 Nominal Voltage: 650 V
 Cooling: Liquid cooled

BATTERY PACKS

Capacity: 113 / 170* kWh
 184 / 276* Ah
 Nominal Voltage: 614 V
 Technology: LFMP
 Charger capacity: 40-80 kW
 Charger type: AC charger
 Charge time: approx. 2 ½ hours
 Maintenance free batteries.
 Designed compliant to ECE R100
 *with optional 3rd battery pack

GEARBOX

Allison, type 3000

Automatic shift transmission with 4 gears forward, 1 gear reverse and torque converter equipped with Lock-Up clutch. Including std. F/R shift protection.

Gear ratio's	theoretical speed (3000rpm) [km/h] (in lock up)	
3.487	14	(F1)
1.864	26	(F2)
1.409	34	(F3)
1.00	48	(F4)

Note: speed is 37km/h@2300 engine rpm
 5.027 10 (R)
 (Tyresize 11R22.5, axle ratio 11.98:1)

FRONT AXLE

VOLVO FA8.2 low

Non-driven steering axle
 Capacity: 11.000 kg (at 20 km/h)*
 * Actual axle load capacity depending on tyre load rating.

REAR AXLE

Terberg TTA type 70-11

Capacity 30.000 kg (at 20 km/h)*
 Hub reduction axle with total reduction ratio 11.98:1

Optional:

- Kessler D81PL478
9.76:1 / 12.73:1 / 16.13:1
 - TTA 70-01 9.49:1
- * Actual axle load capacity depending on tyre load rating.

SUSPENSION

Front: Parabolic leafsprings in rubber mountings with 2 telescopic shockabsorbers.
 Maintenance free system.
Rear: Air suspension with rubber stops

RIMS AND TYRES

Tyres: 11R22.5 (6 pieces)
Rims: 10 stud disc wheels 22.5 x 8.25

STEERING SYSTEM

Fully hydrostatic orbitrol steering system with priority valve and double acting steering cylinder.
 Emergency steering property.
 Steering wheel diameter 350 mm

Turning circle over front bumper (m)
 WB 3400 13,8

5th WHEEL

Terberg 2" cast steel plate

Technical capacity 36.000 kg.
 Lifting capacity 31.000 kg*.
 Automatic locking of jawsystem.
 Pneumatic unlocking of 5th wheel, operated from cabin.
 Indicatorlight for positive locking inside the cabin.

Optional:

- 27.000 kg* lifting capacity (for ultra low 5th wheel height)
 - 34.000 kg* lifting capacity
- * Actual lifting capacity depending on tyre load ratings and 5th wheel height.

HYDRAULIC SYSTEM

Motor driven hydraulic load sensing pump for steering and lifting 5th wheel plate, mounted to the transmission mounted PTO, with priority valve for the steering system.
 Hydraulic oiltank mounted to the chassis frame.
 Tank capacity 127 dm³
 Hydraulic valve electrically operated from inside the cab to lift/lower/hold the 5th wheel. Working pressure 250 bar.
 2 heavy-duty hydraulic single stage liftrams.

CHASSIS

Welded construction of rolled steel channels 200x100x10 mm
 Air reservoirs and battery packs protected mounted to the chassis, access steps with anti-slip surface integrated in chassis.
 Towing pin attachment at front- and rear of chassis.

BRAKE SYSTEM

Full air brake system with split front- and rear-axle and parking brake circuits. Parking brake working on rear axle.
 Front and rear axle equipped with S-cam brake system with automatic slack adjusters.
 Brake pressure: 7,8 – 8,5 bar.
 Air reservoirs: 1 x 40 dm³ and 3 x 30 dm³ with std. airdryer.
 2 Line trailer brake system mounted on rear side of cabin, with yellow and red spiralhoses with glad-hands.

COOLING SYSTEM

Plate type cooler for the liquid cooled power electronics with electric driven fan.
 Electric brushless water pump.
 Separate oil to air transmission cooler.

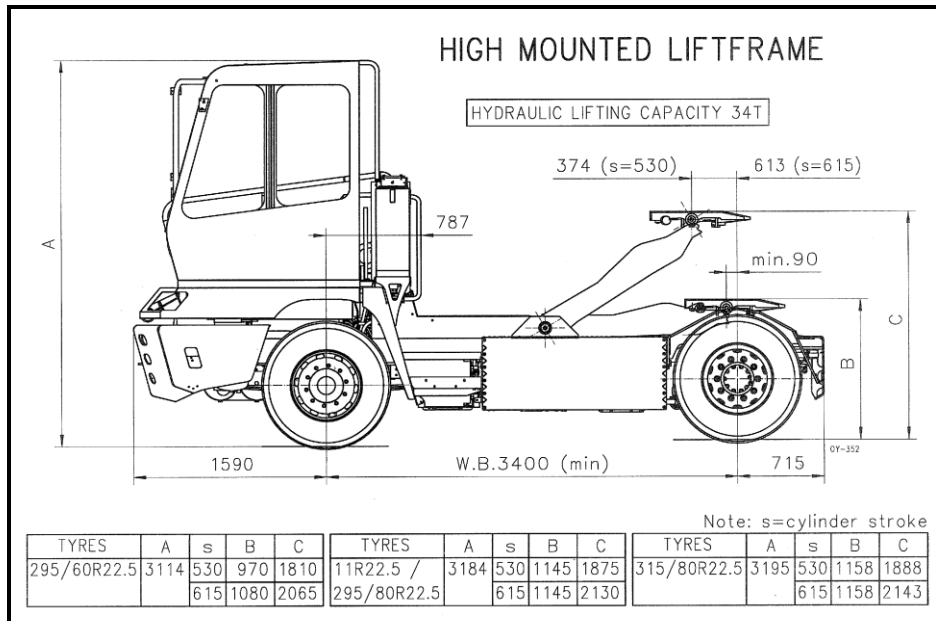

ELECTRICAL SYSTEM (24 Volt)

28 Volt negative earth.

DC/DC converter : 28V/200A
Batteries : 2 x 12 Volt / 25 Ah
Type : semi traction
Fuses and relays mounted in central electrical box.
Wiring with code numbers and easy readable/visible/accessible mounted in central electrical box.
7 pin SAE socket at rear of cab for trailer connection (DIN ISO 1185).
Integrated datalogger, logs history of several operating parameters.

LIGHTING

90 mm bi-LED headlights with main and dipped beam. Combined with 83 mm three function LED with Daytime Running light, direction indicator and position light.

LED rear lights on rear of chassis, with direction indicators and brake lights.
5th wheel floodlight behind cabin.
Gauge illumination.
Interior light in cabin.
Mounting for rotating beacon light.

CABIN

1 person – left hand or right hand drive position.
Forward facing driver's position.

Dimensions outside:

- width : 1400 mm
- length : 1593 mm
- height : 1821 mm

Cabin construction of over dimensioned strong steel profiles to comply to latest Rops/Fops regulations.

Cab mounted on 3 anti-vibration mounts in combination with shock absorber. Entrance to cab by inboard door for safe and easy entrance/exit to/from driver's position.
Horizontal sliding window at driver's side
Large windows with excellent visibility.
All window panes tinted hardened safety glass except front window which is layered.
Noise insulation exceeds international standards.

Cabin can be tilted with hydraulic handpump to 65°
Driver's seat with airsuspension and fully adjustable, mounted on console with generous storage space.

Closed loop temperature controlled emission free electric heater:

- Closed loop temperature control with control display
- Demister/heater
- Variable speed blower
- Recirculation system.

Steering column with 1 brake pedal and 1 accelerator pedal, mounted at right side of column.

Front dashboard switches:

- Ignition
- Motor start
- Emergency button
- Differentiallock
- Worklight
- Hazard lights
- Lighting
- Indicator lights:
 - * Direction indicator
 - * High beam
 - * Differential lock (option)
 - * Handbrake activated
 - * 5th wheel locking status
- Indicator lights/check system with optical signal and/or buzzer on:
 - * High temperature gearbox
 - * Low voltage
 - * Low air pressure circuit 1/2

Display

- State of Charge (SOC)
- Mileage / operating hours
- Engine speed
- Vehicle speed
- System temperature
- Traction system information
- System information
- Air pressure circuit 1
- Air pressure circuit 2
- Battery pack information
- Battery cell data

Panel next to driver seat

- 5th wheel unlocking
- 5th wheel height control lever

Steering column:

- Combi switch for:
 - * Direction indicators
 - * Wiper front
 - * High/Low beam
 - * Horn

Optional:

- Co-driver foldaway seat
- Full electric Air conditioning
- 3rd battery pack
 - * 57 kWh
 - * 92 Ah