



OPERATING CONDITIONS

Outside temperature limits -25°C to +50°C
 Max. GCW RR282:.....2800T @ 0% gradient
 Max. tractive force:170 kN (0.85 friction value)
 Track gauge standard:..... 1435 mm
 Wide track gauge optional: .. 1524 - 1676 mm
 Vehicle weight incl. ballast: 29.000 kg

ENGINE

Mercedes OM936LA (Tier 4f / Stage 4)

Six-cylinder four-stroke direct-injection diesel engine with turbo charging and intercooler. Engine equipped with Mercedes (AdBlue) system including SCR-catalyst.

Displacement: 7,7 dm³
 Bore: 110 mm
 Stroke: 135 mm
 Compression ratio: 17,6:1
 Output: 210 kW (286 hp) at 2200 rpm
 Torque:..... 1150 Nm at 1200-1600 rpm
Acc. to ECE R120

Only for use outside EU/US/Canada:

Mercedes OM906LA (Tier 3 / Stage 3A)

Six-cylinder four-stroke direct-injection diesel engine with turbo charging and intercooler. Engine equipped with engine brake.

Displacement: 6,4 dm³
 Bore: 102 mm
 Stroke: 130 mm
 Compression ratio: 18,0:1
 Output: 205 kW (278 hp) at 2200 rpm
 Torque:..... 1100 Nm at 1200-1600 rpm

** Engine selection depending on operating region and availability. For more info contact our sales team.*

GEARBOX

ZF type 6WG211

Automatic Powershift transmission with 6 forward gears and 3 reverse gears, high

efficiency torque converter with Lock-Up clutch for low fuel consumption and high operating speeds.

Gear ratio Maximum speed (km/h)

5.683F+5.041R	4,0 +4,5	(F1+R1)
3.702F	6,1	(F2)
2.304F+2.044R	9,8+11,1	(F3+R2)
1.501F	15,1	(F4)
0.963F+0.854R	23,6+26,6	(5F+R3)
0.627	36,2	(F6)

Tyres rear axle: 4x 12.00R20 Industrial type
 axle ratio 22.11:1

COOLING SYSTEM

Plate and bar type radiator of heavy-duty construction mounted on rubber silent blocks with separate air-to-air transmission oil cooler and engine intercooler all mounted side by side.

EXHAUST SYSTEM

SCR-catalyst mounted in well protected vertical position behind cabin. Mercedes-Benz AdBlue injection system with heated lines and 35 liter ABS-tank.
Only valid for Tier 4f engine

In case of Stage 3A engine:

Vertical mounted silencer behind cabin with upswept end pipe and protected in critical areas with protection grilles

CHASSIS

Fully welded, solid and very warp resistant ladder frame. Profile measures 200 x 100 x 10 mm. Air reservoirs and fuel tank mounted inside chassis. Access steps with anti-slip surface integrated in the chassis.

FUEL TANK

Steel tank, 400 l capacity. Mounted on top of the chassis counterweight. Very easily accessible from both sides.

FRONT AXLE

Terberg TTA 60

Non-driven steering axle.

Axle load: max. 10.000 kg (at 20 km/h)*

* Actual axle load capacity depending on tyre load rating.

REAR AXLES

2x Kessler D81DPL478

Gear ratio 22.11:1

Axle load max. 15.000 kg/axle (at 20 km/h)*

Axle load in driving condition ±11.500kg/axle

Axle load in rail operation ±10.000kg/axle (total 20.000 kg traction mass)

* Actual axle load capacity depending on tyre load rating.

SUSPENSION

Front: Parabolic leaf springs in rubber mountings with 2 telescopic shock absorbers and additional rubber stops.

Additional air bellow for optimum driving height on road and maximum front wheel lift height when operating on rail.

Rear: Solid walking beam mounting with heavy-duty maintenance-free rubber mounting bushes.

RIMS AND TYRES

Front axle: 2x 11R22.5 on steel rims 8.25x22.5

Rear axles: 4x 12.00R20 on steel rims 8.0x20

TERBERG/ZAGRO RR282 6x4 Road/Rail vehicle

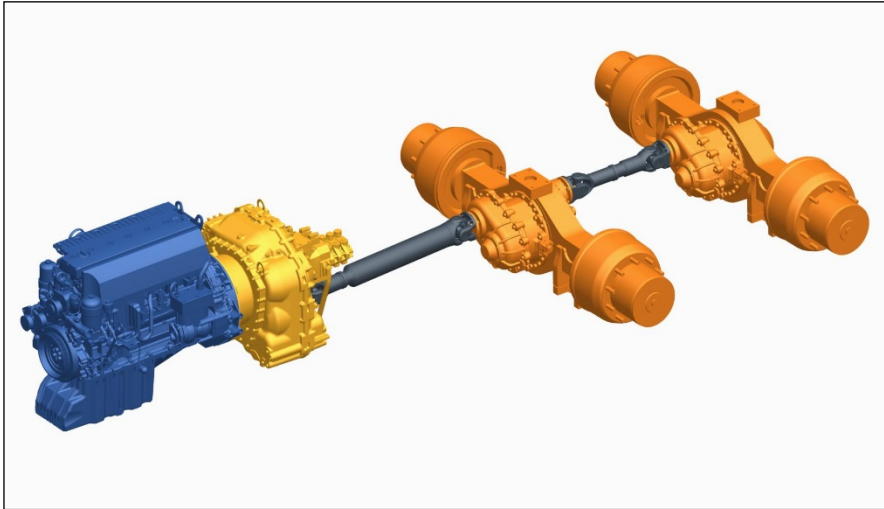

Standard included details:

Speed limiter Road mode max. 25 km/hr
 Speedometer (km)
 Rotating warning beacon
 Wiper washers front & rear
 Intermittent wipers front & rear
 Armrest on seat(s)
 Headrest on seat(s)
 Clipboard A4 size
 Fire extinguisher 2 kg
 First Aid box
 Lockable Diesel / Ad Blue / Engine oil filling caps
 Sun visor(s)
 2 outside mirrors heated
 2 outside wide angle mirrors heated
 1 kerb mirror
 2 interior mirrors
 2 work lights in front cabin / roof height
 Radio CD player
 1 Reversing light in rear chassis
 Side lights LED
 License plate hold + light
 Co-driver's seat with rotating console (180°) makes second operator stand for rail operation with bidirectional trailing load (required control elements are arranged twice)

STEERING SYSTEM

Fully hydrostatic orbitrol steering system with priority valve and double acting steering cylinder. Emergency steering property.
 Maximum steering pressure 175 bar
 Steering wheel diameter 350 mm
 Steering lock angle 48°
 Turning circle over front plate 13,82 m
 Automatic-hydraulic steering wheel locking while rail operation.

TRACTOR BRAKE SYSTEM

Dual-circuit compressed-air brake system for front and rear axles.
 Front axle: S-cam brake system.
 Rear axles: high capacity simplex wedge brake system.
 Automatic slack adjusters front and rear.
 Air reservoirs: 2 x 40 l + 2 x 30 l.
 2-cylinder air compressor.
 Air dryer with integrated pressure reducer.
 Front axle: membrane brake cylinder.
 Rear axles: spring-brake membrane brake cylinders on both axles.

System pressure: 7.8 - 8.5 bar

ELECTRICAL SYSTEM

24 Volt system.
 Alternator : 28 V / 100 A
 Batteries : 2 x 12 Volt / 140 Ah
 Output starter : 5,5 kW
 Fuses and relays easy accessible mounted in central electrical box inside the cabin.
 Wiring with easy readable code numbers.
 All dashboard check/control lights as LED.

LIGHTING

Main headlights with dipped and main beam and direction indicators.
 LED rear lights mounted at rear of chassis, including direction indicators and brake lights.
 2 working lights on rear side of driver cabin.

HYDRAULIC SYSTEM

Engine driven hydraulic vane pump for steering system only.
 Heavy-duty PTO drive on rear of transmission to drive hydraulic piston/gear pumps which drive the rotating compressor (of the wagon brake system) and the track guiding system.

CABIN

Full width, execution for 2 persons.
 Forward facing main driver's position on left-hand side with all necessary controls.

Dimensions outside:

- Width : 2380 mm
- Length : 1593 mm
- Height : 1821 mm

Cabin construction of over dimensioned strong steel profiles to resist latest Rops/Fops regulations.
 Anti-vibration cabin mounting and additionally air-suspended.

Rear cabin door arranged centrally for safe and comfortable entrance and exit.
 Spacious safety windows for excellent panorama view (toned).
 Each 2 sliding windows on driver's and co-driver's side.

Driver cabin can be tilted electro-hydraulically up to 65° for comfortable accessibility of the engine compartment for maintenance work.

2 parallel wipers on front window.
 1 wiper at each rear window.

2 air-suspended Isri 6860 series comfort seats for driver and co-driver with arm rests.
 Adjustable 2-point safety belts. Mounted on console with extra storage space.

Air blower heating/ventilation three-step with recirculation system.
 Air conditioning system.

Front dashboard switches:

- Ignition
- Work light
- Hazard lights
- Lighting

Dashboard display:

Multifunctional full colour CAN-bus display (DIM) showing vehicle speed, brake pressure circuit 1+2, diesel and AdBlue level and engine rpm.
 With possibility to read out running hours as well as the following analogue values (all with optical signal and buzzer on critical levels):

- High temperature gearbox
- Low oil pressure engine
- High temperature engine
- Low voltage

Indicator lights are integrated in the display. It has also integrated diagnostic and vehicle history info which can be shown on the screen and downloaded via USB.

Steering column:

- Combi switch for:
- Direction indicators
 - Wiper front
 - High/Low beam
 - Horn

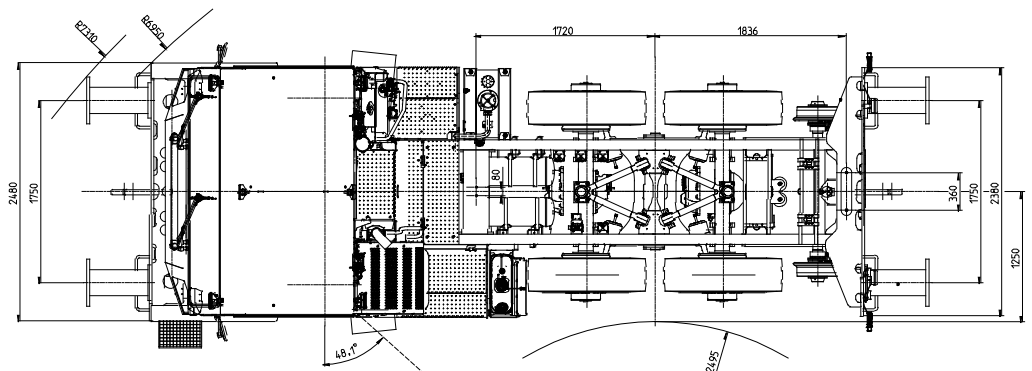

TERBERG/ZAGRO RR282 6x4 Road/Rail vehicle

TRACK GUIDING SYSTEM

- For track gauge 1435 mm
- 2 heavy rail guiding pendulum axles
With each 2 guide wheels Ø 400 mm
- With profile 70° H4020
- Including track sweepers
- Colour monitor with 2 colour cameras as rereiling assistance
- Warp resistant mounting frame rear at the vehicle frame
- Separately controllable hydraulic control for lifting/lowering of the front and rear track guiding with pressure compensation and damping
- Combined ergonomic control unit in the driver cabin
- LCD indication in the driver cabin with optic-acoustic warning in case of hydraulic pressure loss
- Automatic pressure adjustment
- CAN-Bus control
- Automatic fixation of the hydraulic steering at the front axle while rail operation
- Automatic lifting of front axle while rail operation
- Hydraulic safety locking of the rail axles while road operation
- Open-circuit guards directly at the cylinders
- Manual hand pump for lifting of the rail axles in case of vehicle hydraulic failure
- Pneumatically operated foot step with hand grip front right (when shunting configuration)

RAILWAY LIGHTING

Signalling and warning device for public and industrial application.

WAGON BRAKE SYSTEM

- For trailing loads up to 2800 tons, max. 100 axles / 700m wagon length
- Compressor unit with rotation compressor 2500 - 3500 l/min electronically controlled, 10 bar reservoir pressure)
- Electronic hand-brake valve for sensitive control of the wagon brake system
- Air reservoirs with 600 l air reserve
- Each 2 brake hoses (HL=BP + HBL=MRL) with LH3 shut-off cock rear left and right

STANDARD COUPLING SYSTEM

2 buffer as per UIC 526-1 with UIC-hook and mechanical shackle front and rear.

SUPPLEMENTS FOR THE STANDARD COUPLING SYSTEM

- **Automatic shunting coupling RK 900**
Integrated swivelling device.
Pneumatic operation of the coupling head from the driver cabin.
Additional manual emergency release.
Elimination of mechanical shackle.
- **Automatically operated throw shackle**
Pneumatic operation of the throw shackle.
Elimination of mechanical shackle.
- **Customized coupling systems type Scharfenberg 330.**
- **Coupling systems other than UIC on request.**

OPTIONS BASIC VEHICLE

- Driver cabin as right-hand drive
- Elimination of air conditioning
- Engine pre-heating 220V
- Hot water auxiliary heating for heating of the cooling water circuit
- Other optionals on demand

OPTIONS FOR RAIL OPERATION

- Draw bar coupling front and/or rear (not in combination with automatic shunting coupling RK 900)
- Special guide wheel profile according to customer's specification
- Emergency stop switches at all four corners of the vehicle (function: engine stop, apply parking brake, ventilate wagon brake system)
- Illumination of guide wheels
- Camera for supervision of the rear coupling system
- Signalling and warning devices in special execution
- Radio remote control for rail operation (Make Schweizer Electronic OR Laird Theimeg, depending on application and homologation requirements)
- Foot step (pneumatically retractable) with hand grip front left
- Foot step (pneumatically retractable) with hand grip rear right
- Foot step (pneumatically retractable) with hand grip rear left
- Pneumatic sanding equipment
- Standard coupling system front in combination with:
Each 2 brake hoses (HL=BP + HBL=MRL) with LH3 shut-off cock
- Coupling systems other than UIC on request
- Safety deadman system, type Deuta REDsafe
- Inductive train safety device (ATS), type Thales i60R

Tractive Effort Diagram Mercedes OM936LA-210kW - ZF6WG211
RR282 with Lock-Up, GCW 2800Ton (2kg/ton), axleratio 22,11 Tyres 12.00R20XZM

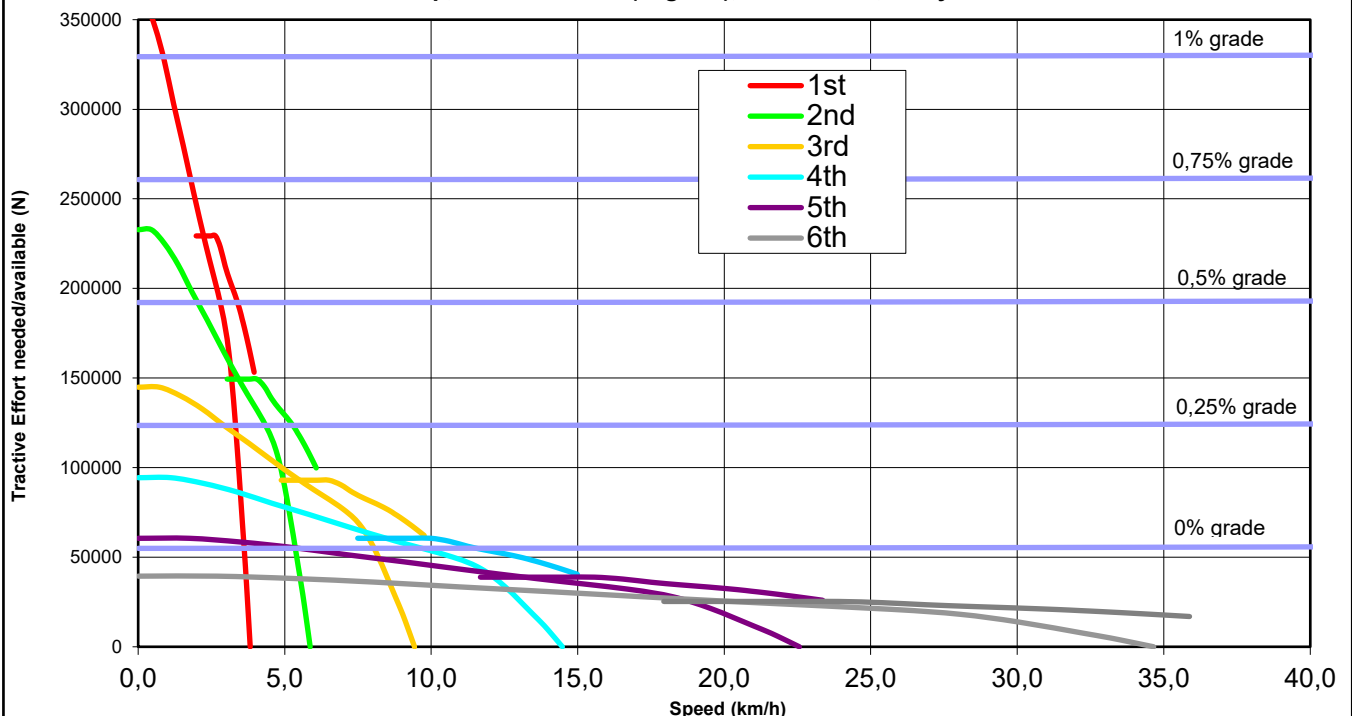

TERBERG/ZAGRO RR282 6x4 Road/Rail vehicle

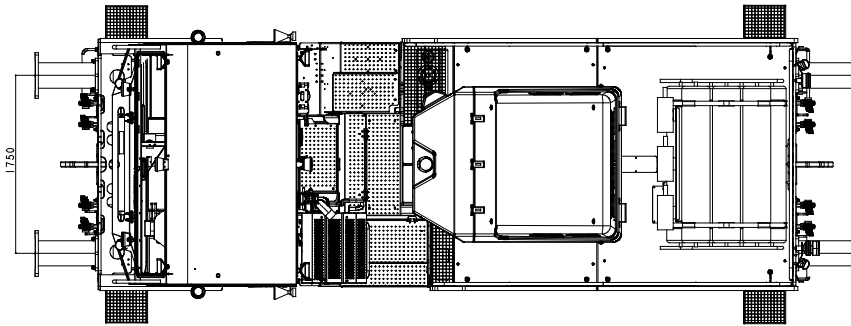
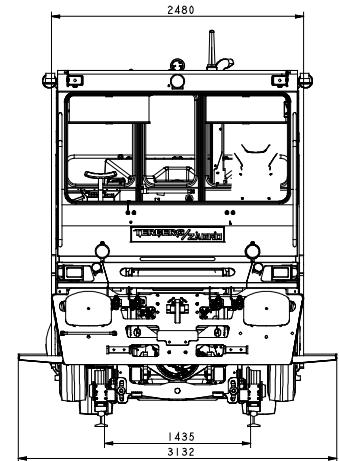
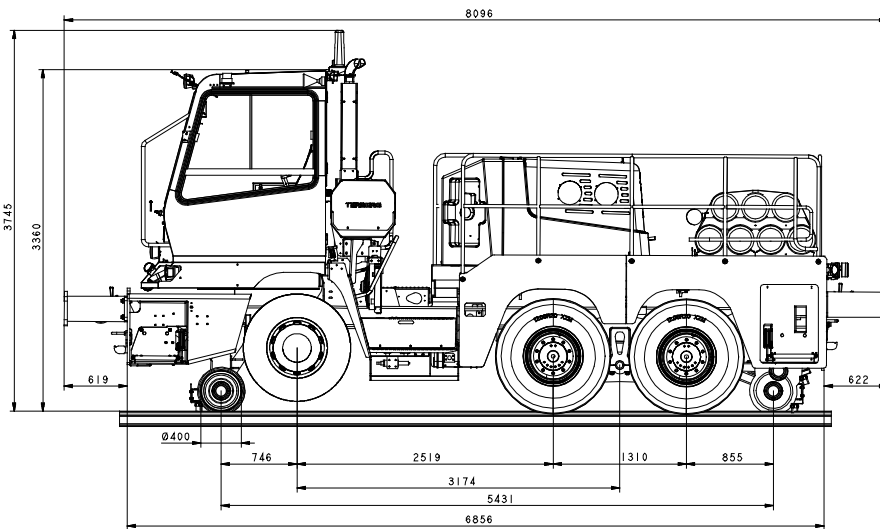

For more information please contact:



 **ncnielsen**
+45 99 83 83 83
info@nc-nielsen.dk
nc-nielsen.dk

 **ncnielsen**
+46 31 53 64 30
info@nc-nielsen.se
nc-nielsen.se

 **ncnielsen**
+47 67 91 99 00
info@nc-nielsen.no
nc-nielsen.no

 **Íslyft ehf**
+354 564 1600
islyft@islandia.is
islyft.is